

PCB manufacturing process

Main Content

- 1. The role of PCB
- 2. PCB classification
- 3. PCB process introduction

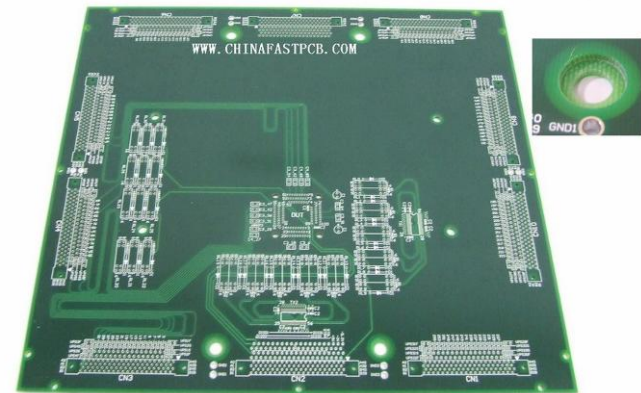

1. The role of PCB

Printed circuit board: PCB

- (1) On the insulating substrate, according to a predetermined design, a printed circuit, a printed component, or a conductive pattern formed by a combination of the two is called a printed circuit.
- (2) On an insulating substrate, a conductive pattern that provides electrical connection between components and devices is called a printed circuit.
- (3) The finished board of printed circuit is called printed circuit board or printed wire board, also known as printed board.

The role of PCB

PCB is an assembly base for completing the combination of the first level of components and other electronic circuit parts, assembled into a module or product with specific functions.

Therefore, PCB plays the role of connecting all functions in the entire electronic product. Therefore, when the function of the electronic product fails, the first suspect is often the PCB, and because the PCB processing process is relatively complicated, the production control of the PCB is particularly strict and important.

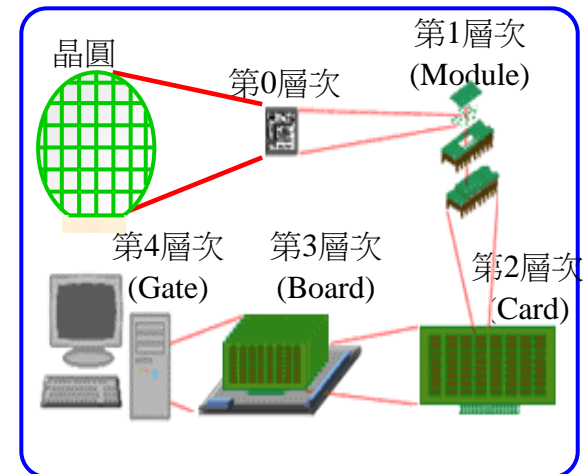

2. PCB classification

PCBs are diversified in materials, layers, and manufacturing processes to suit different electronic products and their special needs.

Therefore, there are many types of divisions. The following summarizes some common differences to briefly introduce the classification of PCB and its manufacturing process.

★ By layers

a. Single layer; b. Double-layer; c. Multilayer ;

★ By nature

a. Rigid board b. Flex-board c. Rigid-flex board

★ By structure

a. Ordinary multi-layer board b. HDI board c. Blind buried hole board d. Cavity board. ...

★ By product application

a. Gold finger card board b. Communication system board (system board, backplane, system HDI board) c. IC substrate board d. High frequency and high speed board e. Other consumer electronics products (such as mobile phone board, computer motherboard, power supply Board, metal substrate, etc.



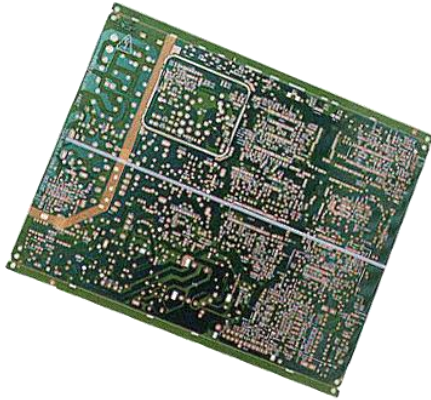

← Single layer

Double-layer

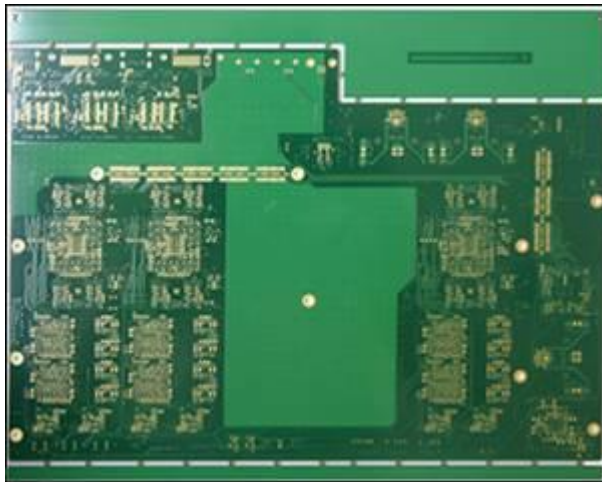
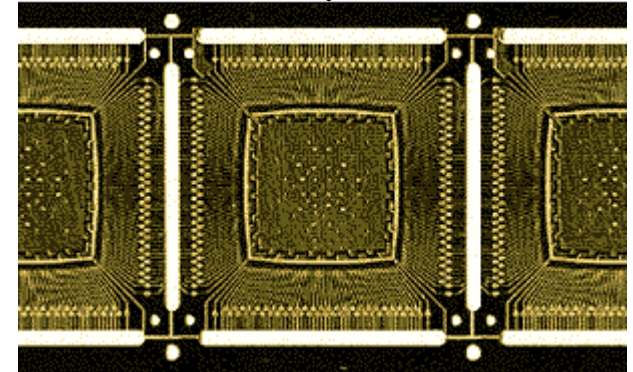

← Multilayer PCB



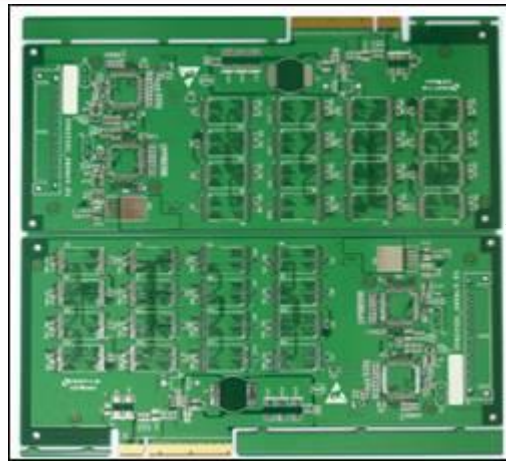

Rigid PCB

Rigid-flex PCB

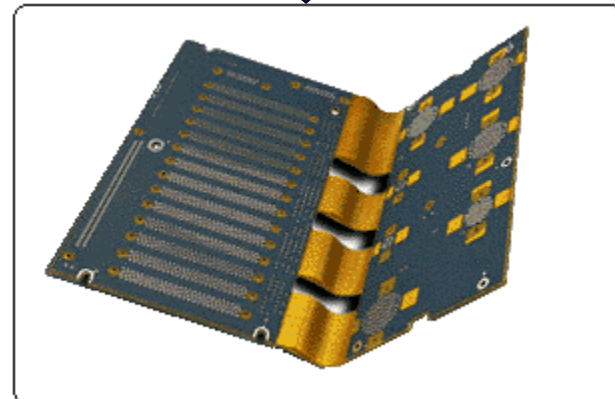

Flexible PCB

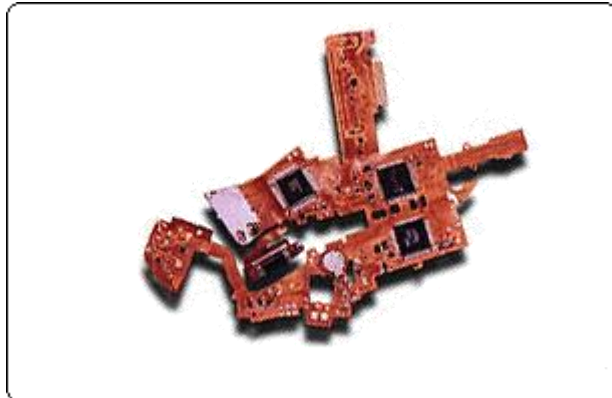

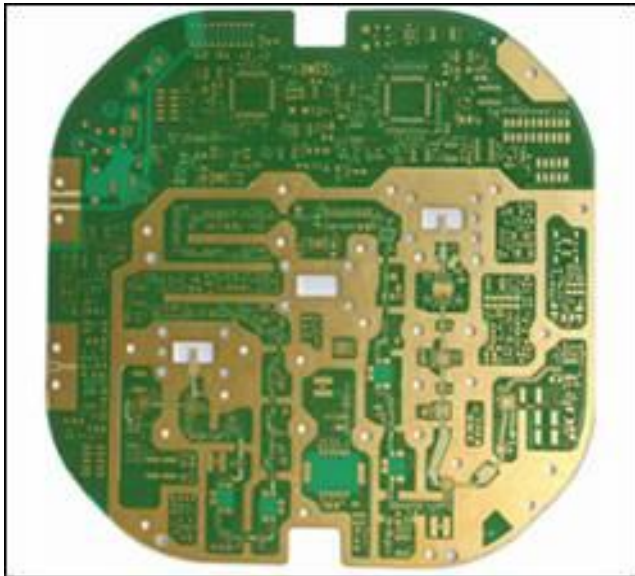
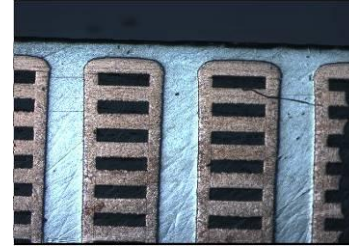
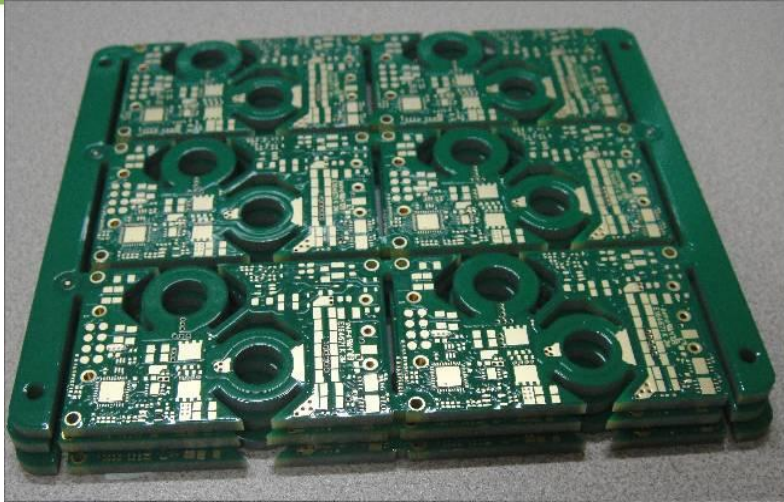

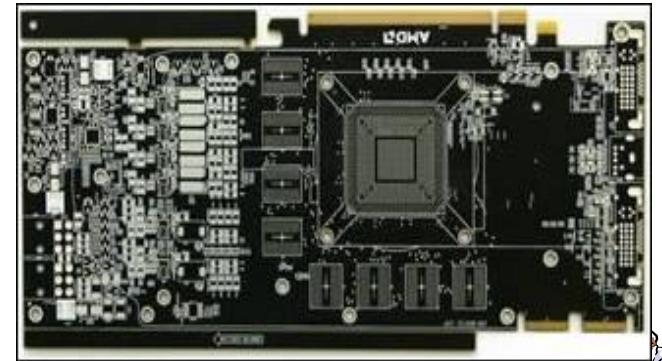
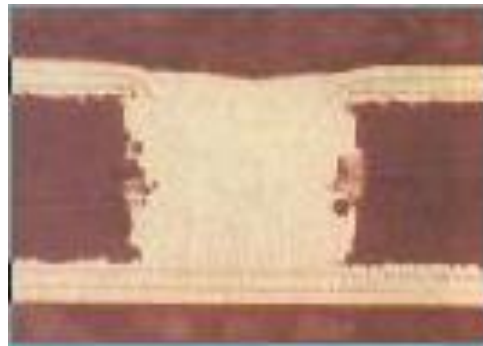
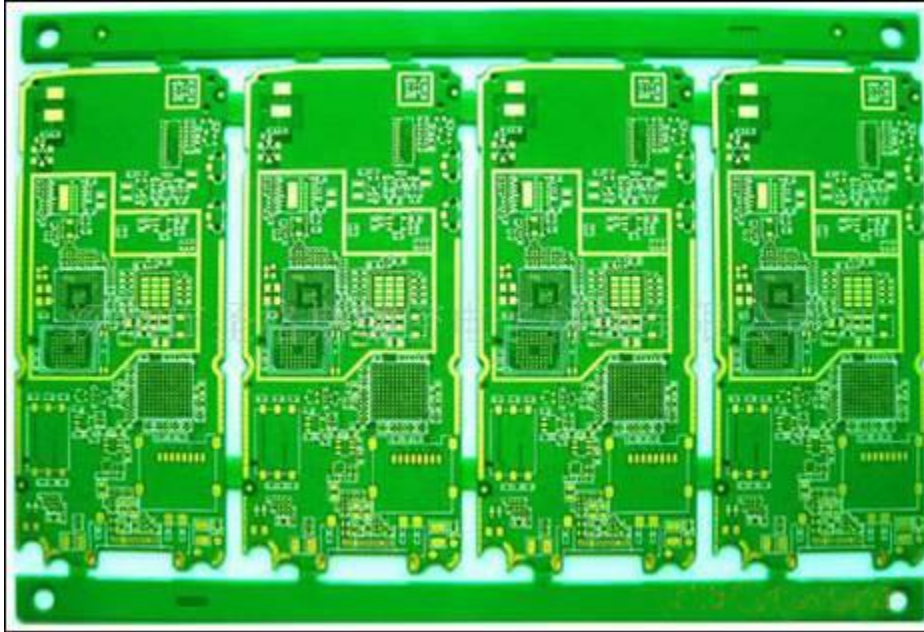

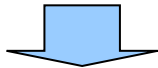
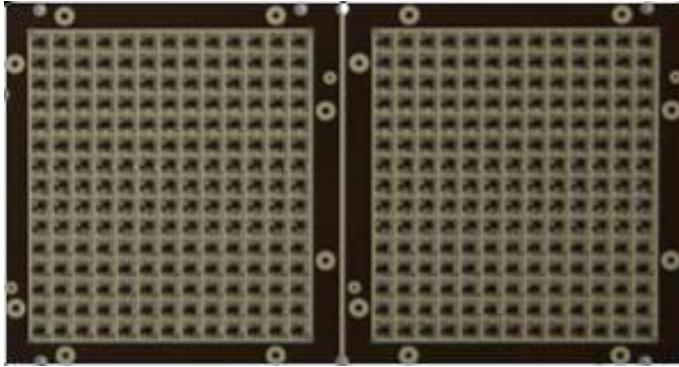

← 26L



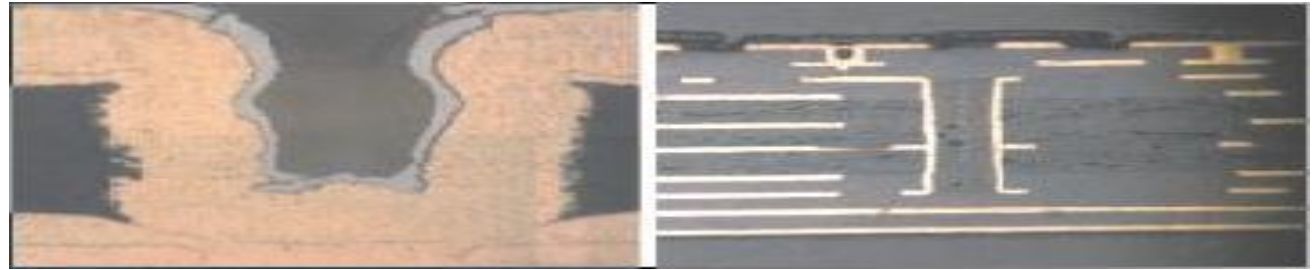
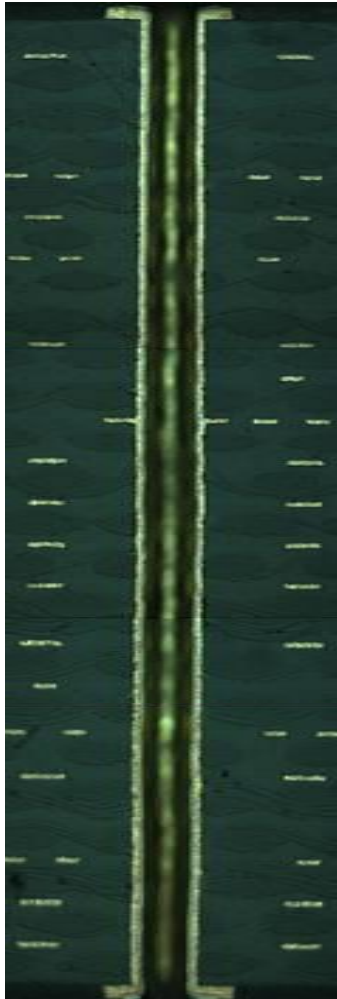

☆ Take the multi-layer board process as an introduction to the PCB process, The process is as follows:

A. Inner graphics transfer

(Development & Dry Film)

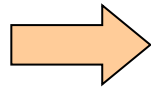

B. Lamination

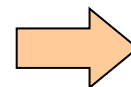

C. Drilling
(Laser drilling)

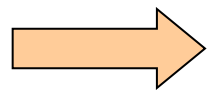

D. Immersion copper plating (PTH)



E. Outer graphics transfer

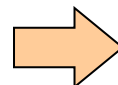

F. Soldermask/silkscreen

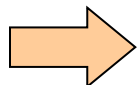

G. Surface treatment

(HASL&ENIG&...)

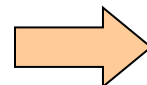

H. Profiling

(Outline milling)

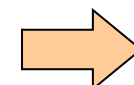

I. Last process

(ET&FQC)



A. Introduction of the inner circuit process

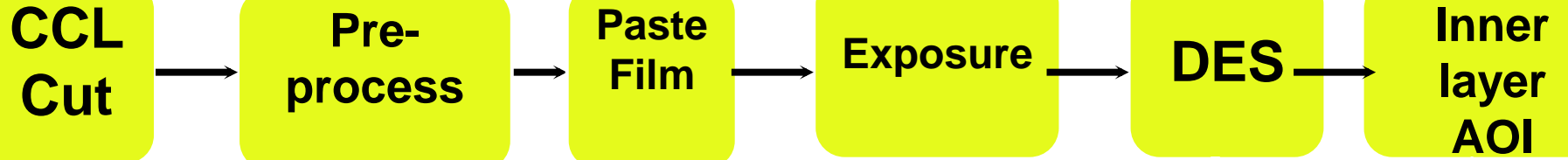

Purpose:

- Making use of graphic transfer principle to make inner circuit
- DES is abbreviation of Development, Etching and Strip film

Inner layer circuit- BOARD CUT

BOARD CUT:

Purpose: According to the planning requirements of the engineering design institute, the substrate material is cut to the required size for production

Main production material: copper clad laminate

Copper clad laminate is formed by laminating copper foil and insulation.

There are different thickness specifications according to requirements.

According to copper thickness, it can be divided into H / HOZ; 1 / 1oz; 2 / 2oz and other types

Matters needing attention

- Considering the influence of inflation and shrinkage, the cutting board is baked before being sent to the next process.
- The cutting must pay attention to the same latitude and longitude direction as the engineering instructions to avoid warpage and other problems

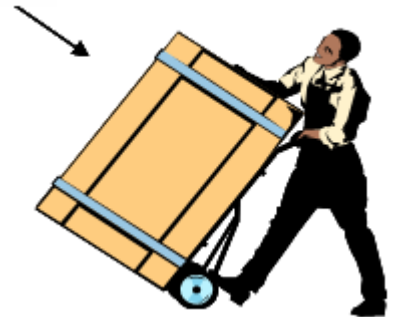

PRETREAT:

Purpose:

Remove the contaminants on the copper surface through the micro-etching solution, increase the roughness of the copper surface, and facilitate the subsequent lamination and circuit fabrication.

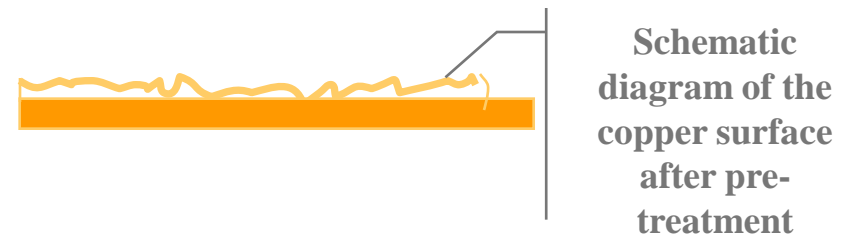
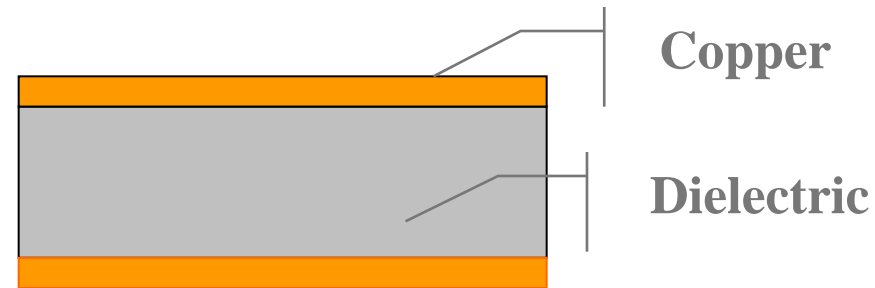

Inner layer circuit- Paste the film

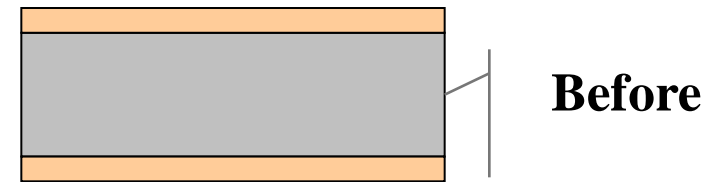
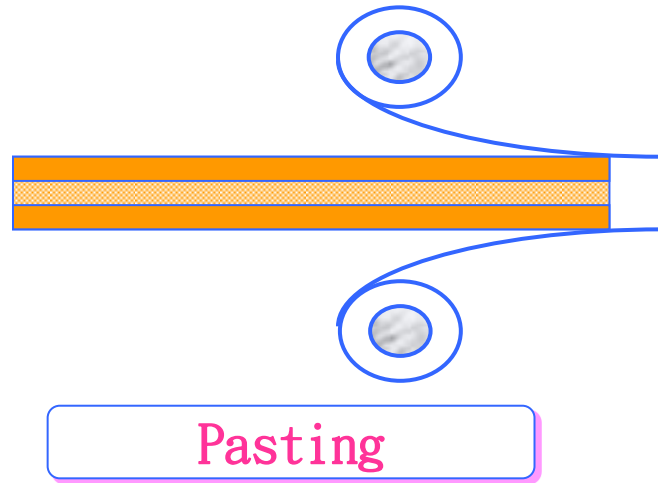

Dry
film

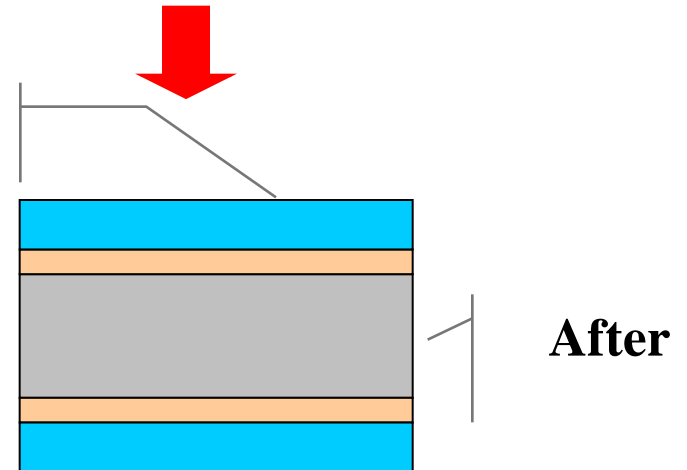

- **Pressing film**

Purpose: Paste the copper surface of the treated substrate through a hot pressing method. The main production material: dry film (Dry Film)

Inner layer—Exposure introduction

EXPOSURE:

Purpose:

- The image on the original negative film is transferred to the photosensitive substrate by light irradiation
- Main production tools: film
- Process principle: The photo-polymerization reaction occurs in the white light-transmitting part, and the black part does not transmit light due to opacity, and the reacted part cannot be dissolved and left on the board surface during development

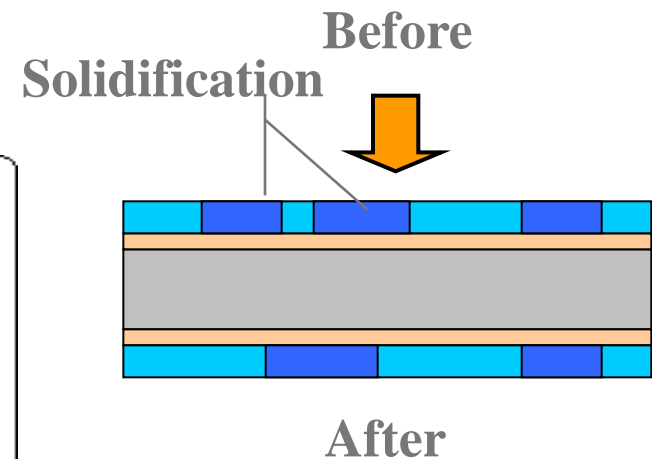
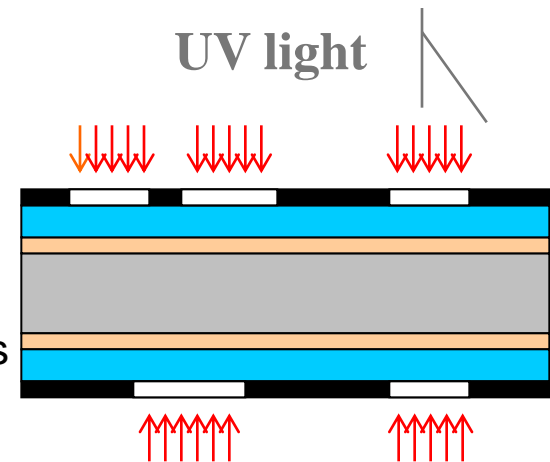
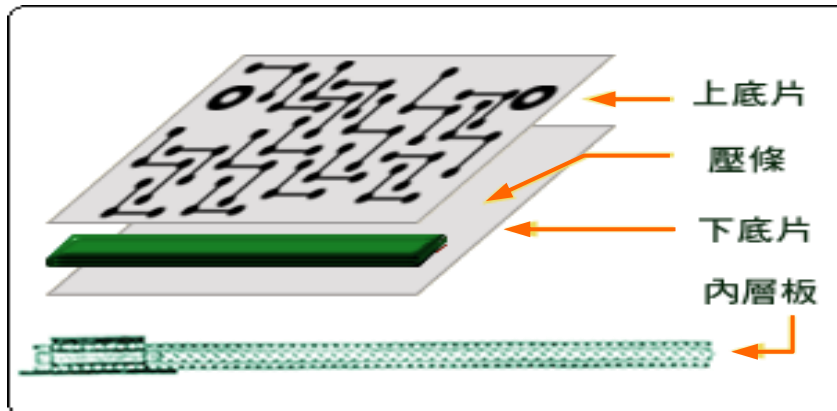

Inner layer circuit-development

- **DEVELOPING:**
- Purpose: Wash off the dry film that has not undergone chemical reaction with the action of lye
- Main production materials :**K₂CO₃**
- Process principle: The dry film that has not undergone polymerization reaction is washed away, and the dry film that has undergone polymerization reaction is left on the surface of the board as a corrosion protection layer during etching.
Description: The water-soluble dry film is mainly due to its composition containing organic acid radicals, which will react with weak alkali to make it become an organic acid salt, which can be dissolved by water and reveal the graphics

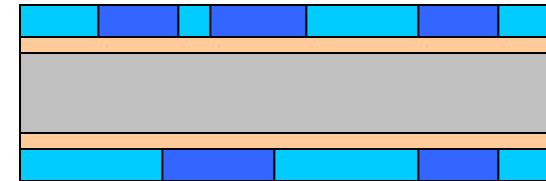

Before



After

Inner layer circuit-etching introduction

- **ETCHING:**
- Purpose: Use the chemical solution to etch away the copper exposed after development to form the inner layer circuit pattern.
- Main production material: etching chemical solution (CuCl_2)

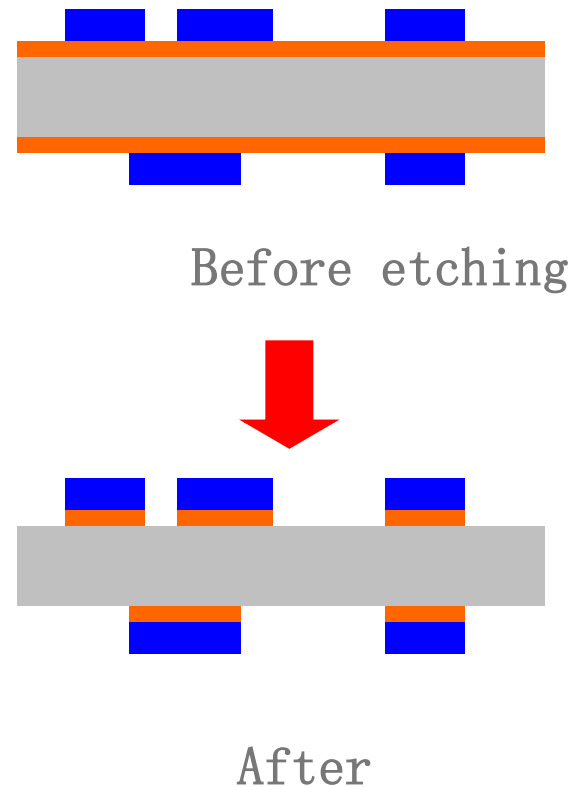

STRIP:

- Purpose: Use strong alkali to peel off the resist layer that protects the copper surface to expose the circuit pattern.
- Main production material: NaOH

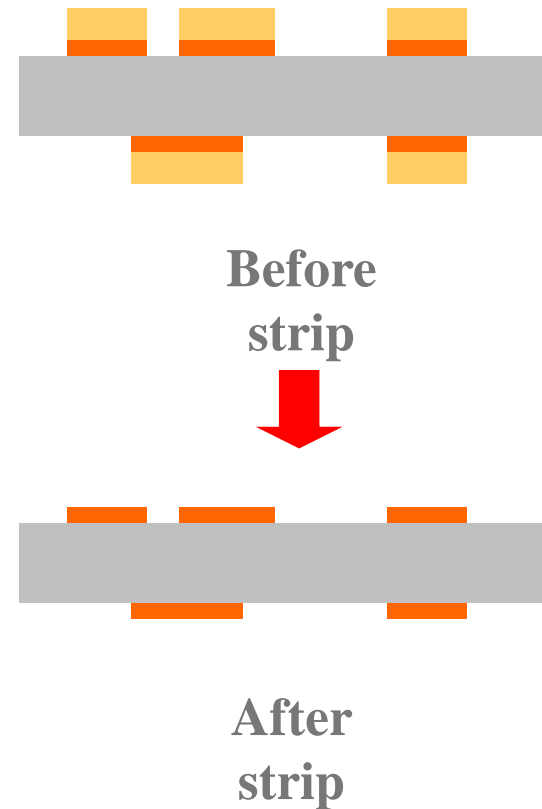

Inner layer-punching

Punching

- Purpose: Use CCD to align the positioning holes and rivet holes of the inspection operation.
- The main production materials:
drill tool

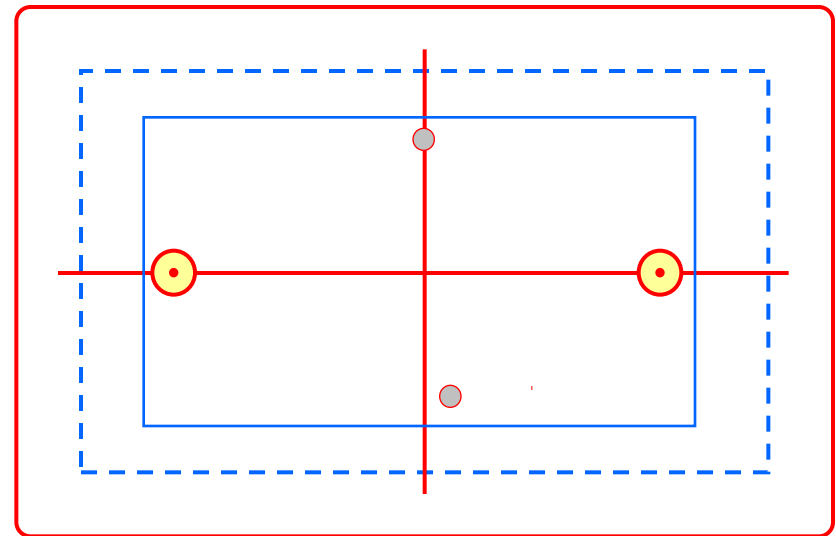

Inner layer AOI

- **AOI: Automatic Optical Inspection**
- Purpose: The image is fed back to the equipment for processing through the principle of optical reflection, and compared with the set logical judgment principle or data graphics to find out the shortcomings.
- Notes: Since the test method used by AOI is logical comparison, there will be some misjudgment , the shortcomings need to be confirmed manually.

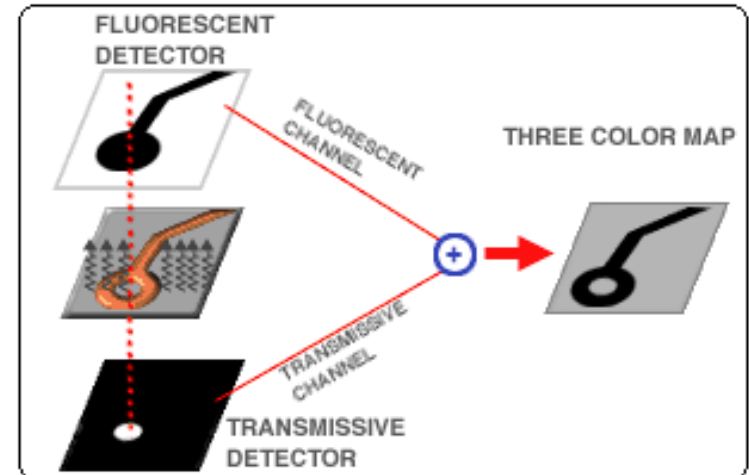
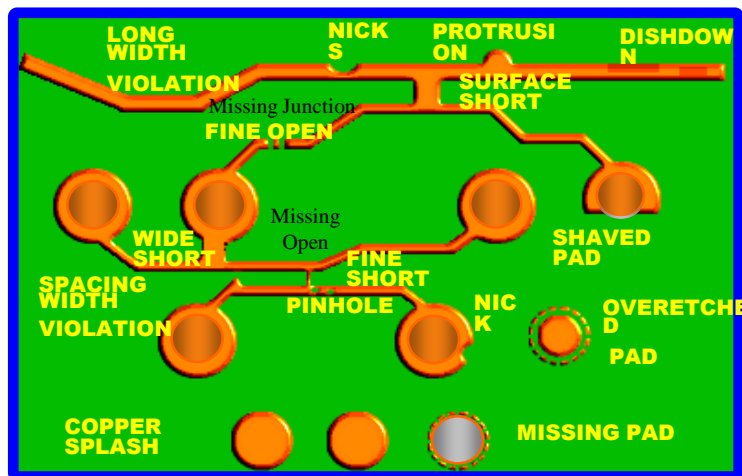

Introduction

Press the photosensitive resist on the copper foil substrate, use the exposure machine to transfer the desired image to the photosensitive film (on the copper foil substrate) through the negative film, and then develop, etch and strip the polymerized photosensitive film through chemicals film out the required image (circuit); finally use AOI for circuit maintenance to complete the inner circuit production.

Main process

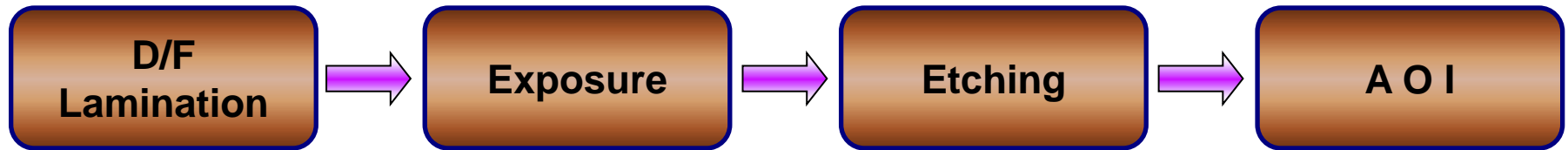

Inner layer circuit process overview

Physical map



Before paste

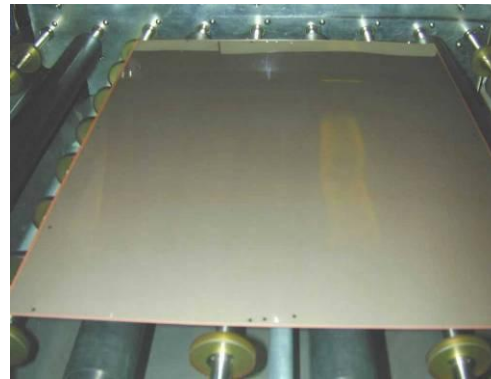

After paste

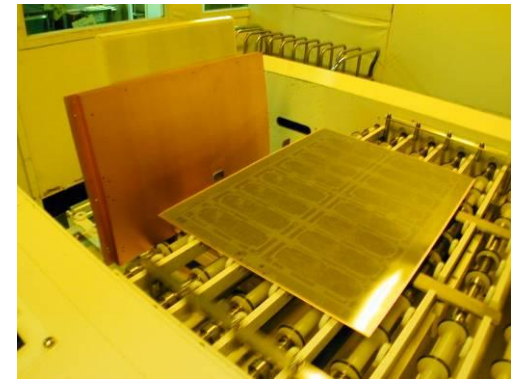

After exposure



Develop



Etching



Strip

B. Lamination process introduction

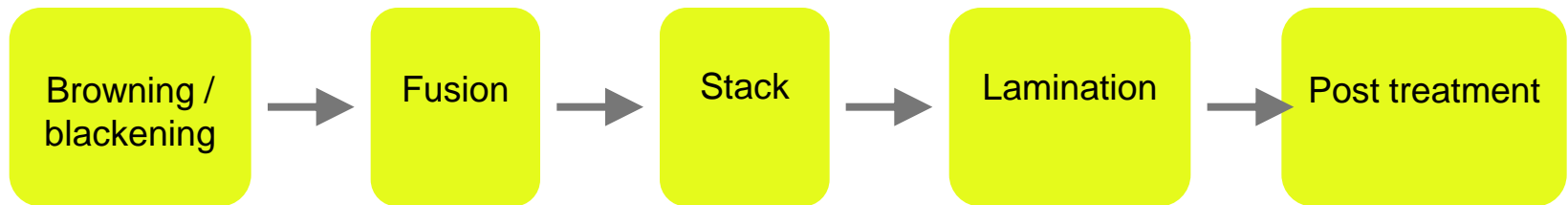

Purpose

To compress copper foil (Copper), Prepreg and browning inner layer circuit board into multilayer board.

Browning / blackening

Purpose

- 1) Roughening the copper surface and increasing the surface area of contact with the resin
- 2) Increasing the wettability of the copper surface to the flowing resin
- 3) Passivating the copper surface to avoid adverse reactions

Notes: The Browning film is very thin, which is prone to scratching problems.

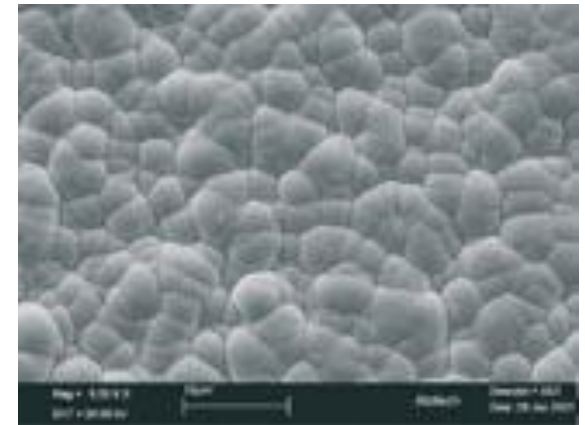

Horizontal browning line



Riveting

Purpose: (Four-layer board does not require rivets)

First, melt glue, fix each core board, and then use rivets to nail multiple inner layer board together to avoid inter-layer slip during subsequent processing.

Main production Material: rivets; prepreg (PP)

PP: It is composed of resin and glass fiber cloth.

According to the type of glass cloth, it can be divided into 106, 1080, 3313, 2116, 7628 and other resins.

The resin can be divided into: A-stage (completely uncured); B-stage (semi-cured); C-stage (fully cured) three categories, all used in production are P / P in B-stage

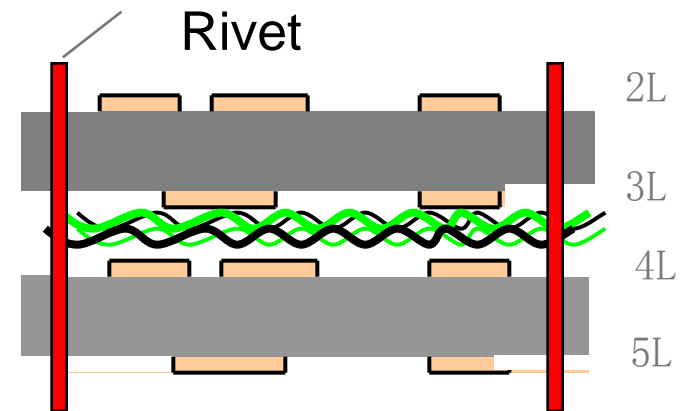

Stacked board:

- Purpose: The pre-laminated board is stacked into a multi-layer board to be pressed.
- The main production materials:
copper foil, semi-cured sheet
electroplated copper skin;
- According to the thickness, it can be divided into
 - 1 / 3OZ = 12um (code T)
 - 1 / 2OZ = 18um (code H)
 - 1OZ = 35um (code 1)
 - 2OZ = 70um (code 2)

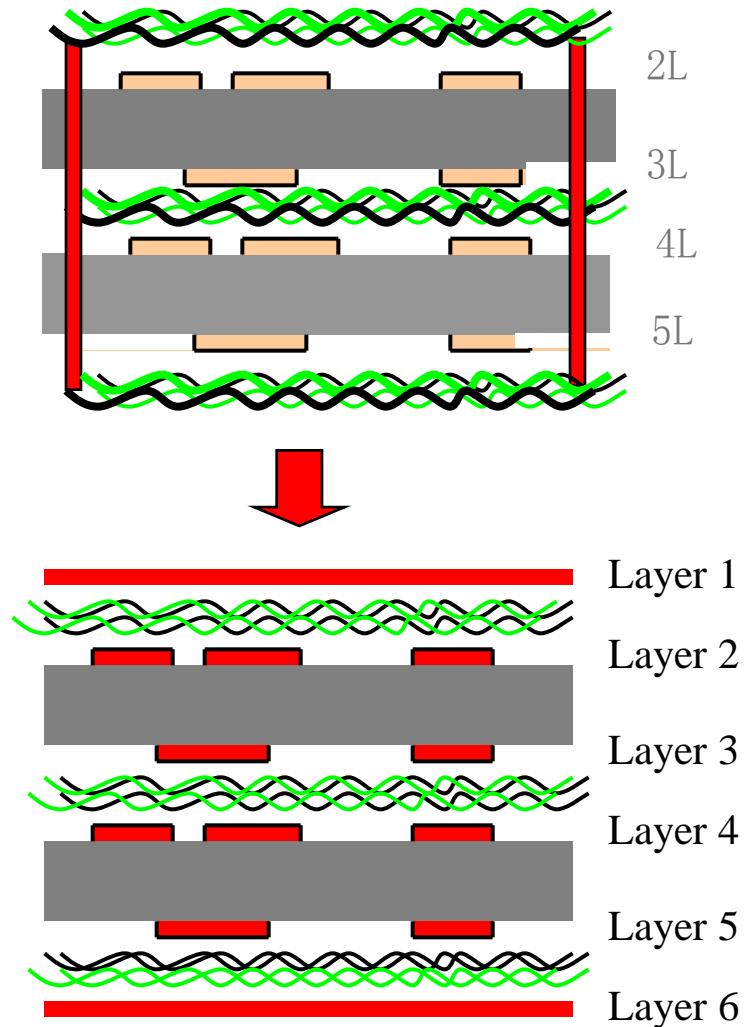

Lamination Process-Pressing

Pressing

Purpose: Press the laminated board into a multi-layer board by hot pressing.

Main production accessories: kraft paper, steel plate

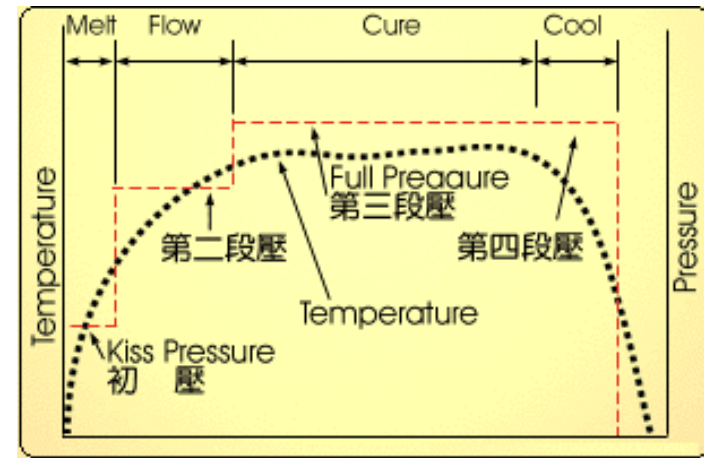
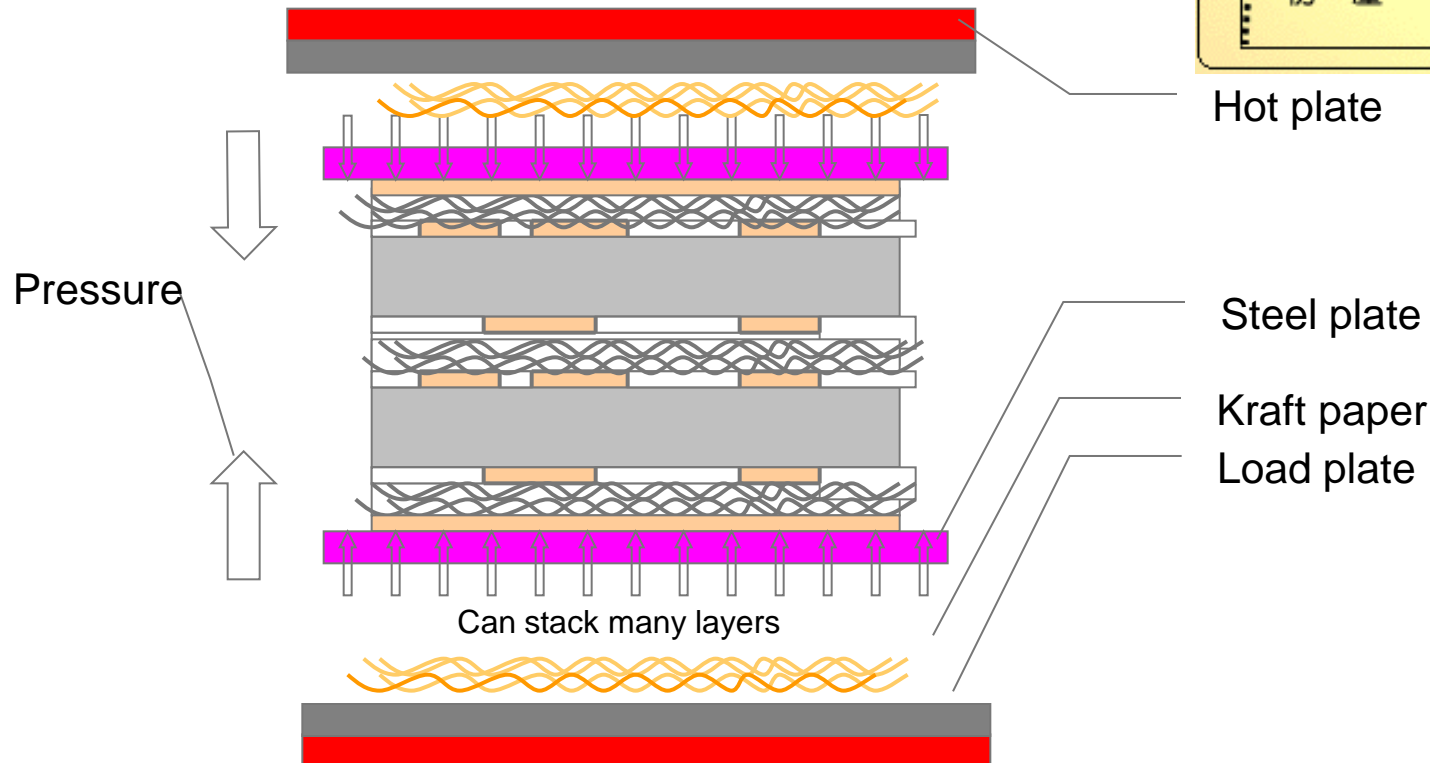

Hot plate

Steel plate

Kraft paper

Load plate

Introduction

According to the laminated structure of the design, the PP film, copper foil and the blackened inner layer board are laminated, and then the laminating machine is pressed under a high temperature and high pressure environment to cause strong adhesion between the layers in order to ensure the board thickness and interlayer specifications required by customers, and expand the upper and lower copper surfaces for wiring.

The main process

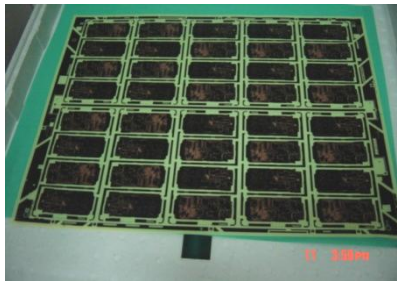
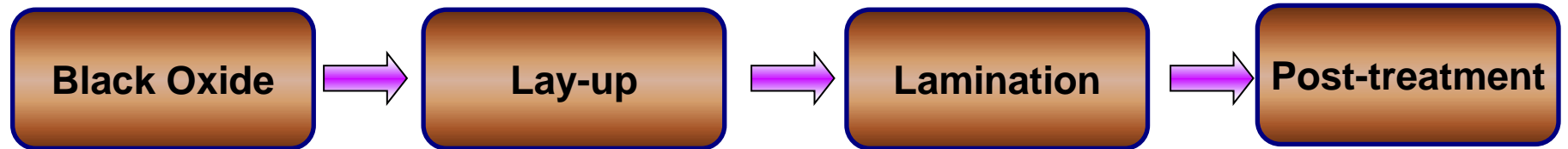

Physical flow chart



Before Black Oxide

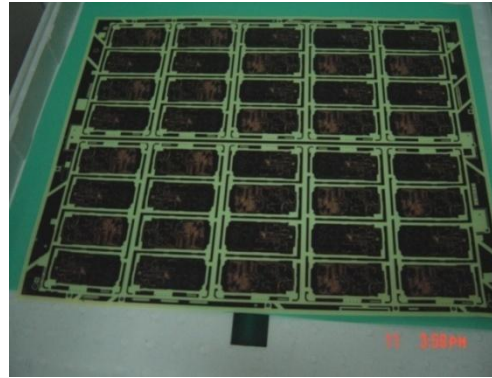

Black Oxide

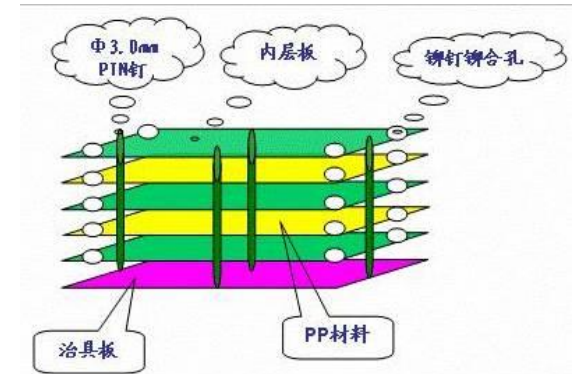

Make up



Stack

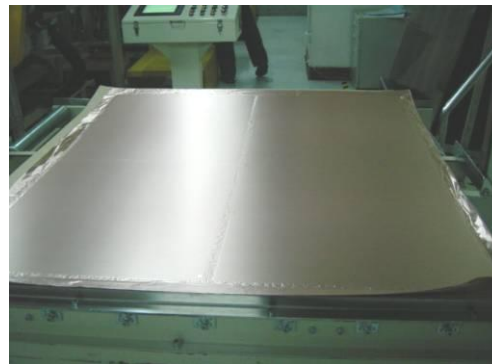

After Lamination

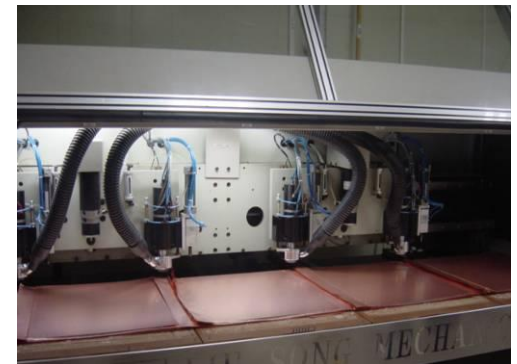

After routing

C. Introduction of drilling process

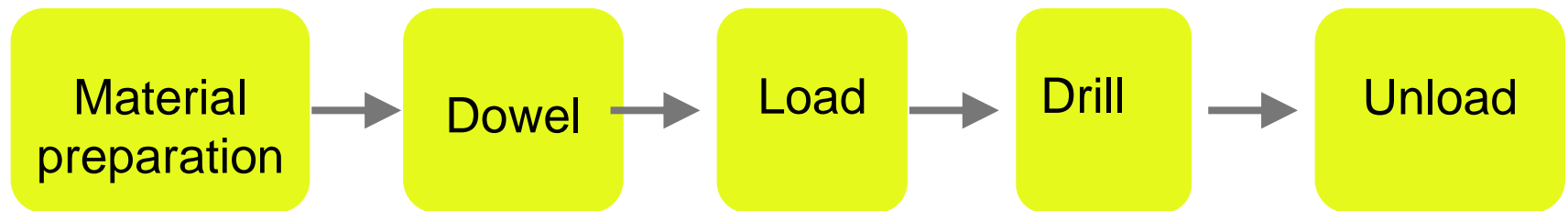

Purpose

To drill through holes or all non-through holes in the board to connect circuits between layers.

- **Main raw materials:** drill bit; cover plate; backing plate
- **Drill bit:** combination of tungsten carbide, cobalt and organic adhesive.
- **Cover plate:** mainly aluminum sheet, which is used to position the drill bit during the manufacturing process; heat dissipation; reduce burr; prevent pressure foot pressure injury
- **Backing plate:** mainly a composite board, which protects the rig table during the manufacturing process; prevents export burrs; reduces the temperature of the drill and cleans the slag of the drill

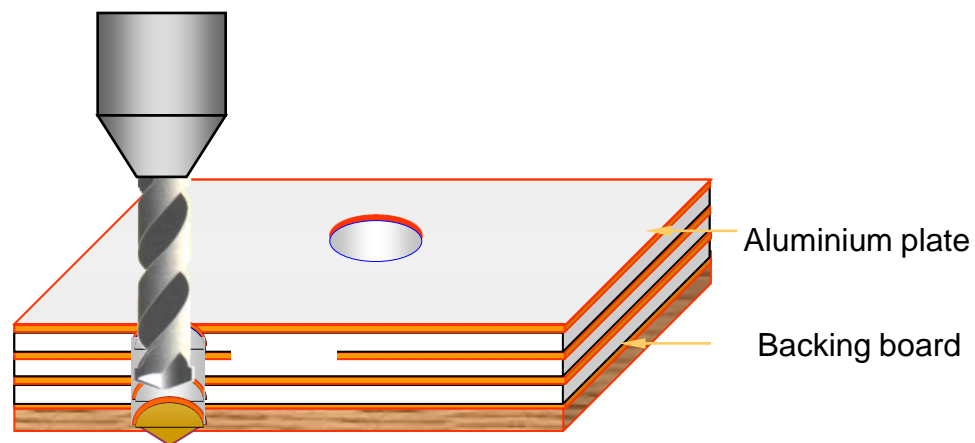

High speed drilling machine



Introduction

According to the hole size requirements of the customer, corresponding apertures are drilled in the plate to facilitate the insertion of the assembly; it can also play the role of layer-to-layer conduction, heat dissipation, fixation, etc.

Main process

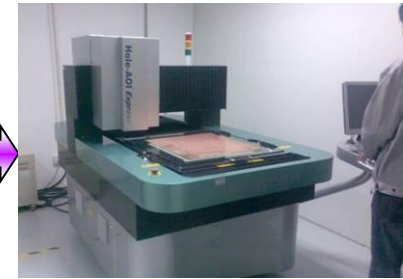
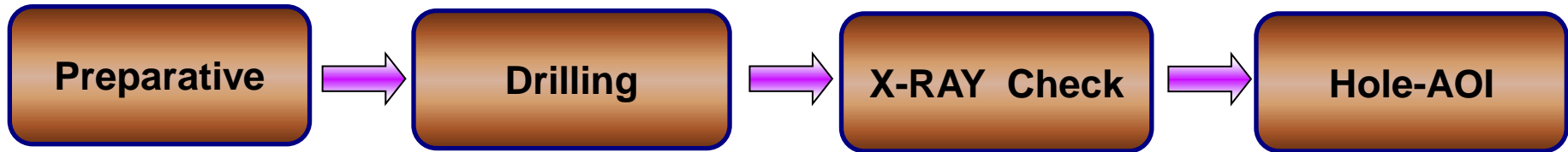

D. PTH Electroplating Process

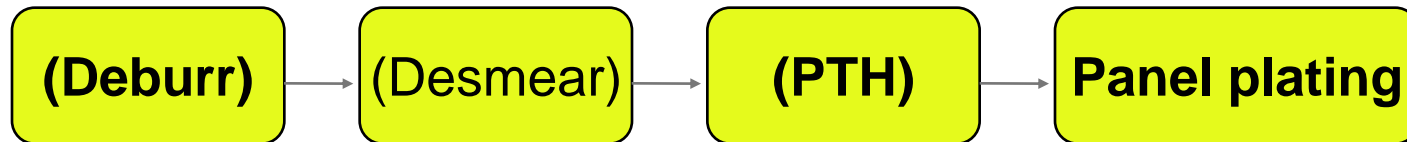

Purpose

- ♣ To metalize the resin and glass fiber of the non-conductor part of the hole wall
- ♣ Facilitate the subsequent electroplating process, and provide a metal hole wall with sufficient conductivity and protection

☺ Deburr:

Reasons for the formation of burrs: uncut copper wire and glass cloth at the edge of the hole after drilling. The purpose of deburring: to remove the burrs at the edge of the hole to prevent poor plating.

Important raw materials: abrasive brush

☺ Desmear:

♣ Reasons for the formation of glue slag: the high glass transition temperature (T_g value) caused by drilling, which forms a molten state, which produces glue slag

♣ The purpose of removing glue slag: expose the copper rings to be interconnected in each layer, and another leavening agent can improve the hole wall structure and enhance the adhesion of electroplated copper.

Important raw materials: KMnO_4 (glue remover)

PTH Process-Introduction to PTH

☺ PTH

- ♣ The purpose of chemical copper(PTH): to deposit chemical copper with a thickness of 20-40 micro inches on the surface by chemical deposition.
- ♣ Hole Wall change process: as shown below
- ♣ Principle of chemical copper: as shown on the right

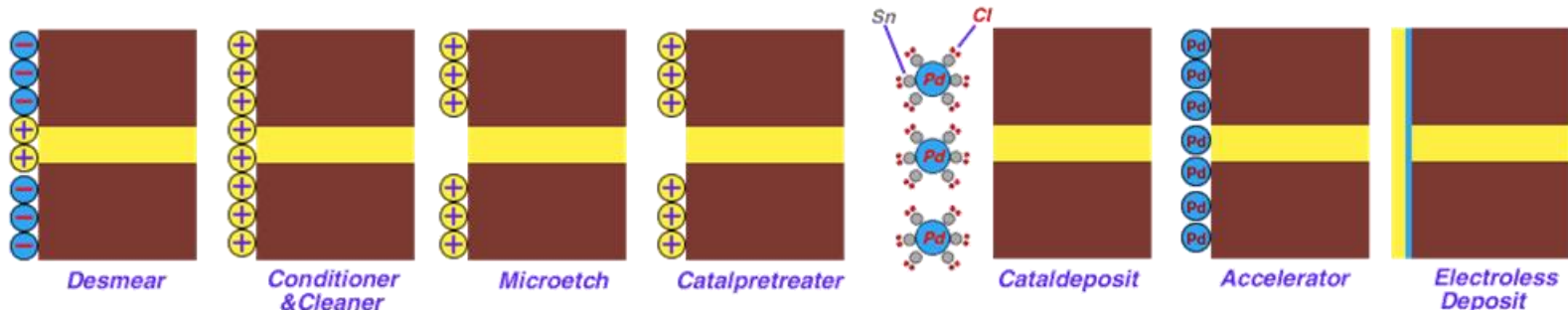
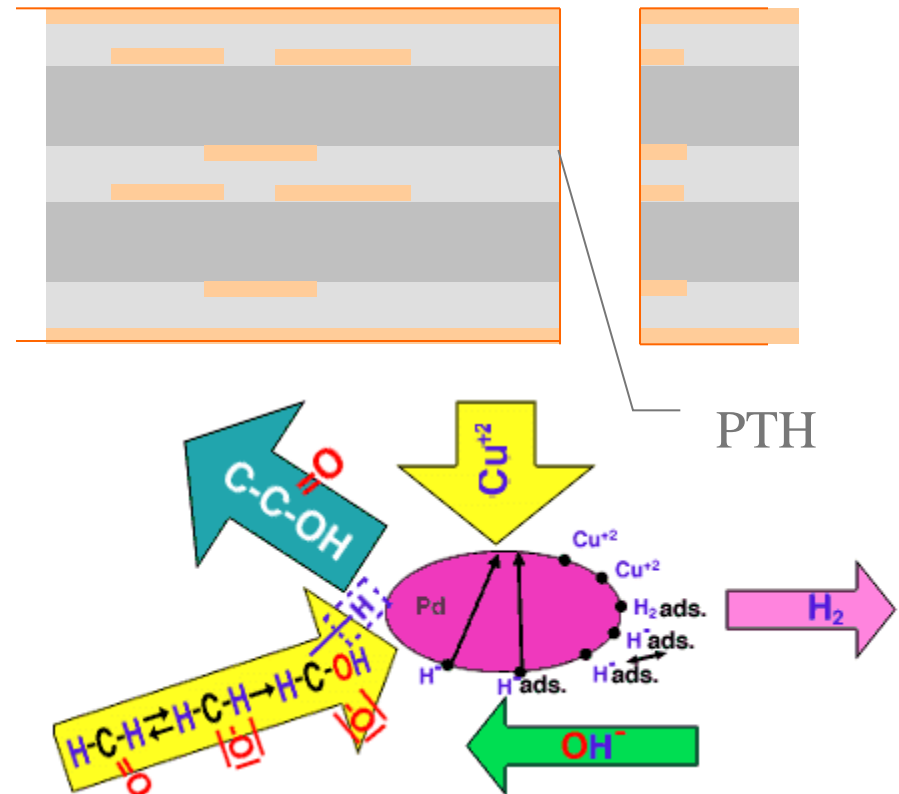

☺ Copper electroplating

- ♣ Purpose of primary copper: Plating copper with a thickness of 200-500 microinches to protect the chemical copper with a thickness of only 20-40 microinches from being damaged by the post-process and causing hole break.
- ♣ Important production materials: copper ball

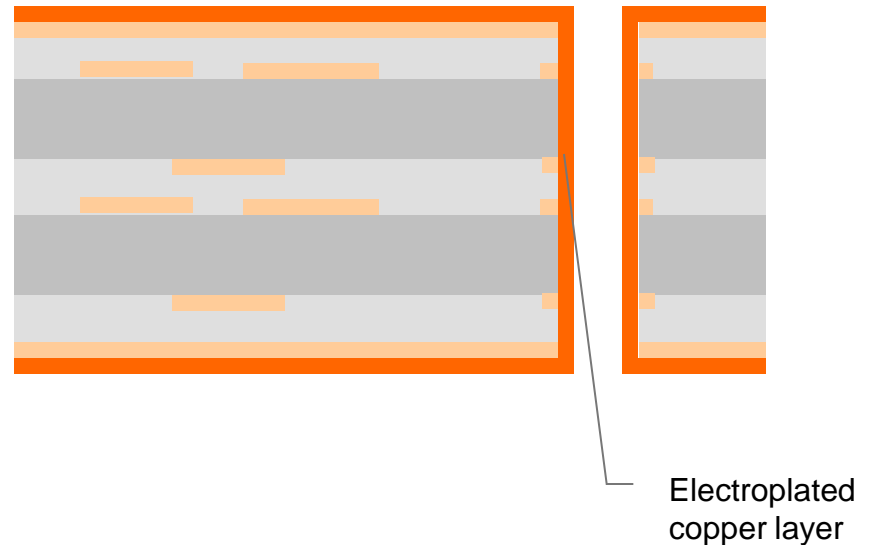

E. The outer circuit process

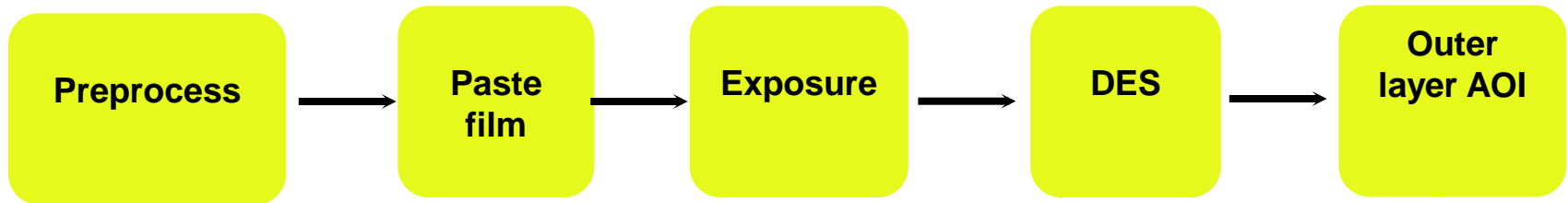

Outer graphics transfer

The outer layer circuit processing can be divided into acid etching process and alkali etching process.

Acid etching process

- The outer layer acid etching process is the same as the inner layer circuit process.

Alkali etching process

The alkaline etching process is a few steps longer than the acid etching process. In contrast to the acid etching process, the positive film is used. After the hole is thickened, copper plating is thickened, After development, it is subjected to secondary copper plating and tin and lead plating to protect the circuit pattern, and then undergoes stripping, etching, and tin removal Process, and finally present the circuit graphics.

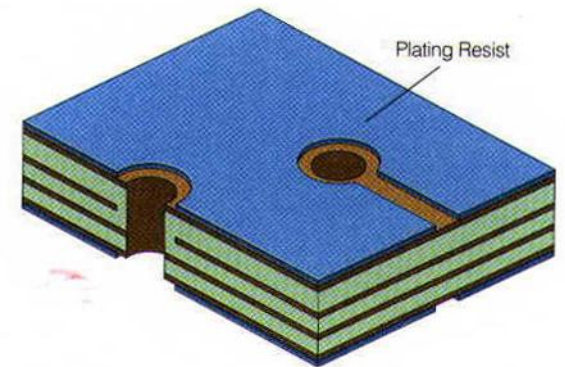
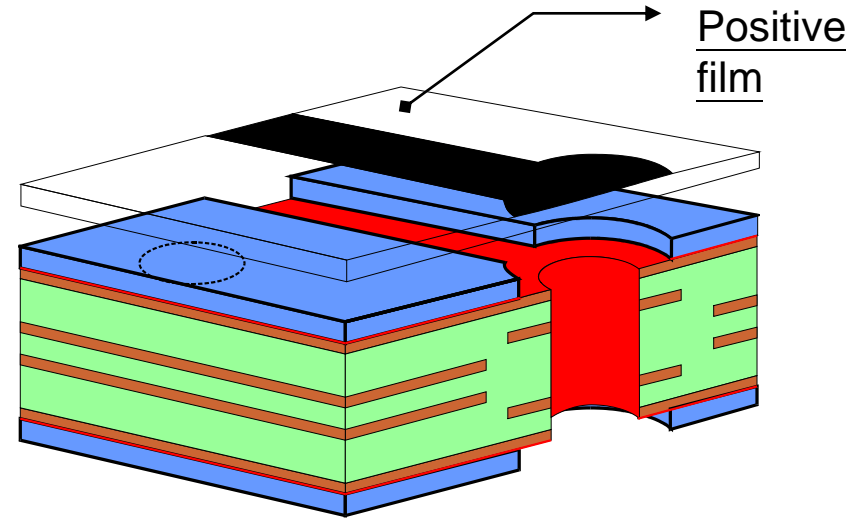
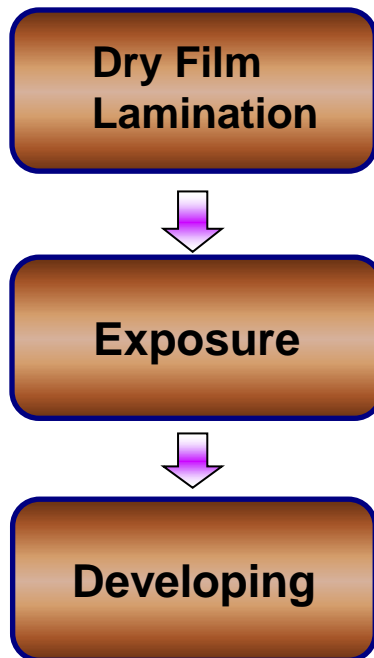

Illustration ML-8. Apply plating resist. The desired circuitry is left uncovered.

Alkali etching process

Copper Plating



Tin/Lead Plating

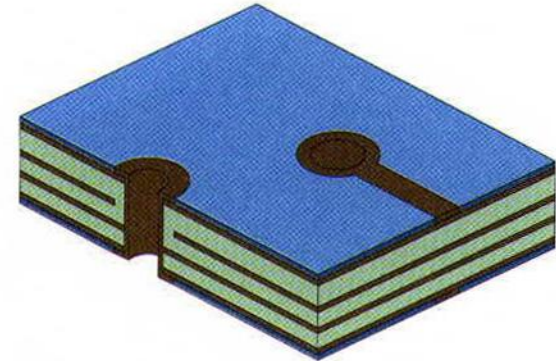

Illustration ML-9. *Electroplate copper.* The specified thickness is electrolytically deposited (usually 0.001").

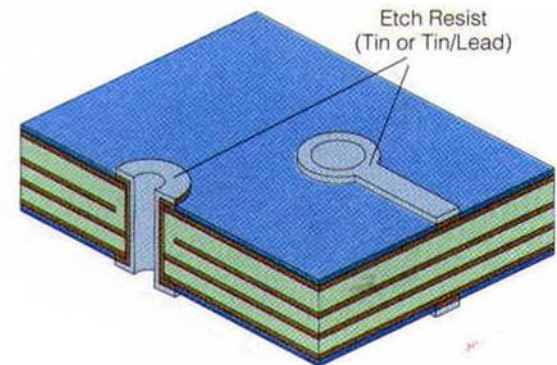

Illustration ML-10. *Electroplate etch resist.* Tin or tin/lead is electrolytically deposited over the copper plating.

Alkali etching process

Stripping



Etching



Tin/Lead Stripping

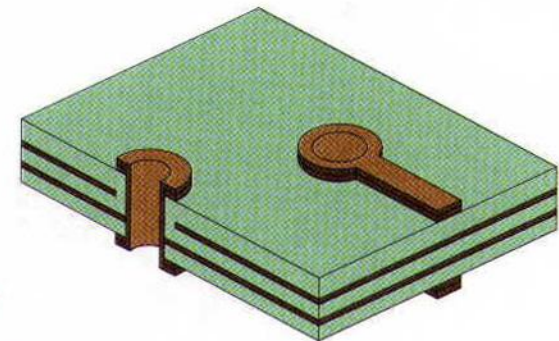
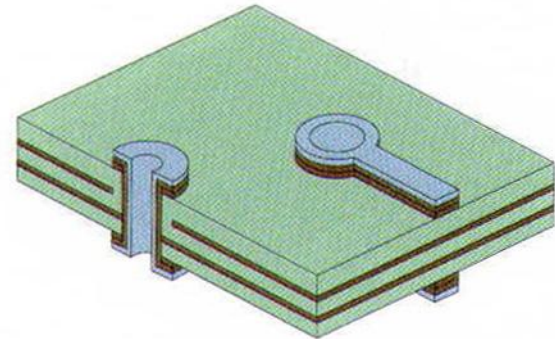
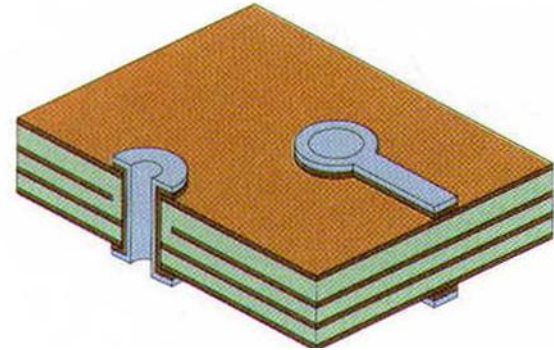

Illustration ML-13. Strip etch resist. The tin or tin/lead is chemically removed.

Volcanic
Ash
Grinding
Board

Green
oil silk-
screen

Pre-bake

Exposure

Develop

Silkscreen

Solidify

Solder Mask Over Bare Copper

Purpose

- ♣ The protective layer of the outer circuit to ensure the insulation, shielding and anti-soldering of the PCB.
- ♣ Make character identification.

Solder Mask

Solder mask, commonly known as “green oil”, in order to facilitate visual inspection, so the main paint is added to the green pigments that are helpful to the eyes, In fact, there are yellow, white, black and other colors in addition to the green soldermask.

- A. Solder-proof: Leave the through-holes and pads to be soldered on the board to cover all circuits and copper surfaces to prevent short circuit caused by wave soldering
- B. Protect board: prevent moisture and various electrolytes from oxidizing the circuit and jeopardizing electrical performance, and prevent external mechanical damage to maintain good insulation of the board surface

C. Isolation

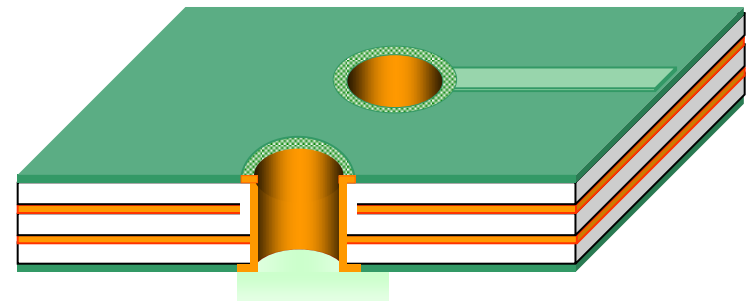

- **Exposure**

Purpose : Image transfer

Main equipment: Exposure machine

Process key points:

A. Exposure machine cleaning

B. Energy selection

C. Vacuum control

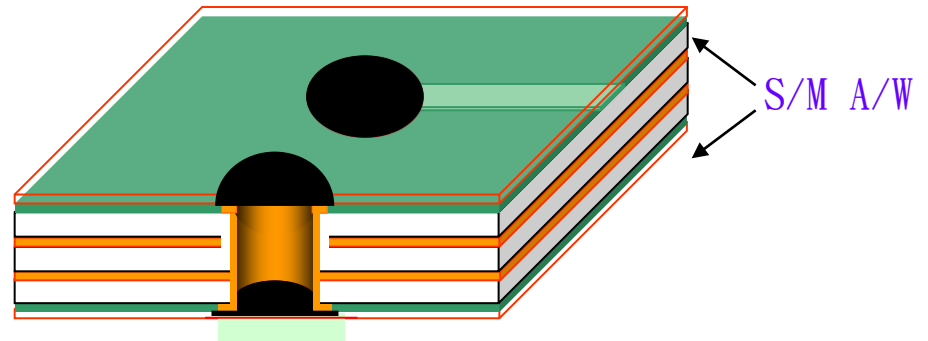

Development

Purpose: To remove unpolymerized photosensitive ink with a potassium carbonate solution with a concentration 1%.

Main production material:
potassium carbonate

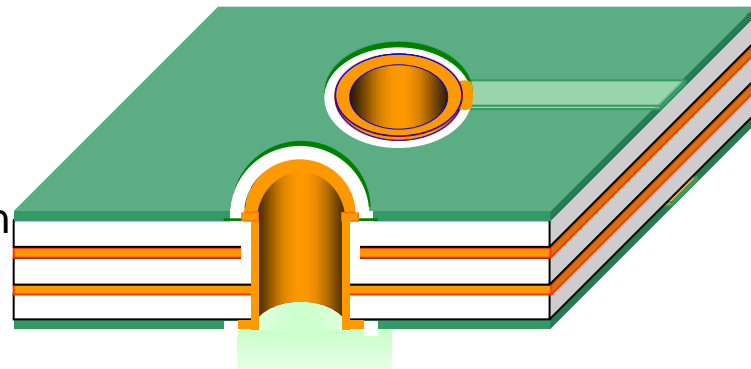

Silkscreen-Introduction to Printing

Printing silkscreen Purpose:

Facilitating maintenance and identification

Principle: Screen printing method

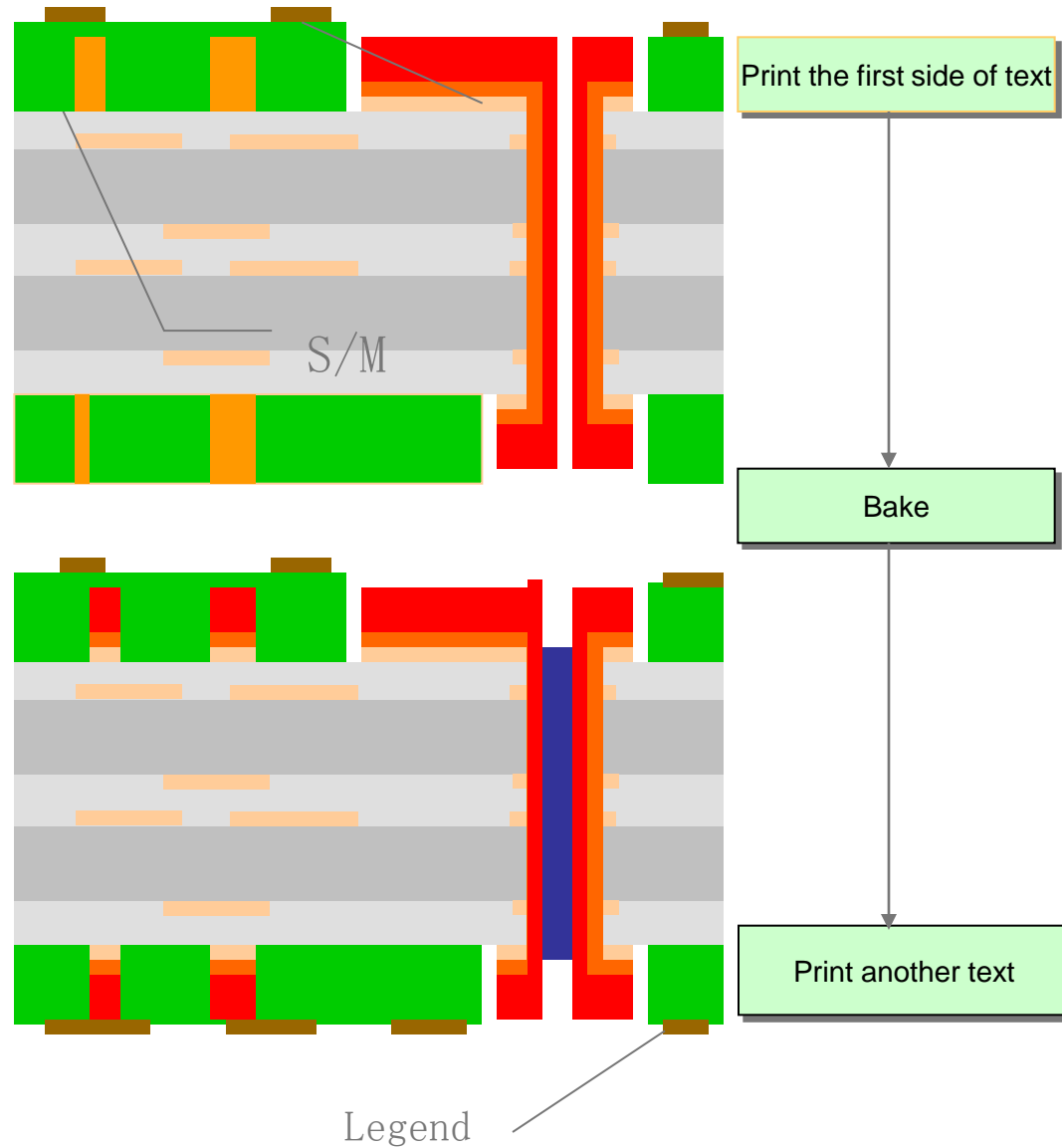
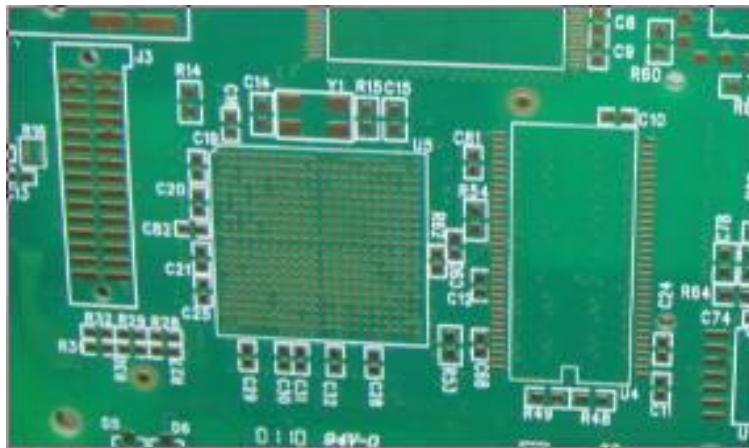

Silk screen printing machine



Silkscreen solidify

Solidify(post-baking)

Purpose: To completely harden the epoxy resin in the ink through high-temperature baking.

G. Introduction of surface technology

A conventional printed circuit board (PCB) has copper layers on the board. If the copper layer is not protected, it will be oxidized and damaged, which directly affects the subsequent soldering.

There are many different protective layers that can be used, the most common ones are: Hot Air Leveling (HASL), OSP, Plating Nickel & gold, Immersion Nickel Gold (ENIG), Gold Finger, Immersion Silver and immersion Ti etc.

- **(1) Hot air leveling (HASL):** After the board is completely covered with solder, then the high-pressure hot air is used to blow off the excess solder in the surface and the hole, and the solder attached to the pad and the hole wall is leveled; there are lead soldering and lead-free soldering two kinds.

Advantages: low cost, maintain solderability throughout the manufacturing process

- **(2) Organic coating (OSP):** A thin, uniform protective layer is formed on the copper surface of the PCB

Advantages: Comparable with HASL in cost, good coplanarity, lead-free process

- **(3) Plating gold:** plating nickel and protective gold on copper surface by electroplating.

- Advantages: good weldability, flat surface, long storage life, can withstand multiple reflow soldering.

- **(4) ENIG:** Replace the nickel-phosphorus layer on the copper surface through a chemical reaction, and then replace a layer of gold on the nickel layer.

Advantages: good solderability, flat surface, long storage life, can withstand multiple reflow soldering

- **(5) Gold finger:** Nickel and gold are electroplated on the edge copper surface of board by electroplating, because gold plating contains other metals, it's different with (3).

- **(6) Immersion Silver:** Silver is immersed in a 0.1 to 0.6 micron metal layer on the copper layer to protect the copper surface.

Advantages: good weldability, smooth surface, natural replacement of HASL immersion.

- **(7) Immersion Tin :** Tin is immersed in a metal layer of 0.8 to 1.2um on the copper layer to protect the copper surface.

Advantages: good weldability, smooth surface, relatively low cost.

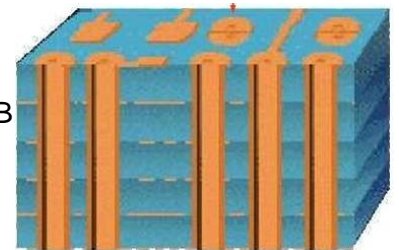

H. Outline processing

Milling machine (forming) process

Cut the PCB board into the shape required by the customer, remove the useless frame waste on the periphery, and remove the dust on the board surface, hole, V-cut, slot after mechanical forming, and provide PCB boards that meet the specifications, easy for customers to assemble.

Routing



Rinse

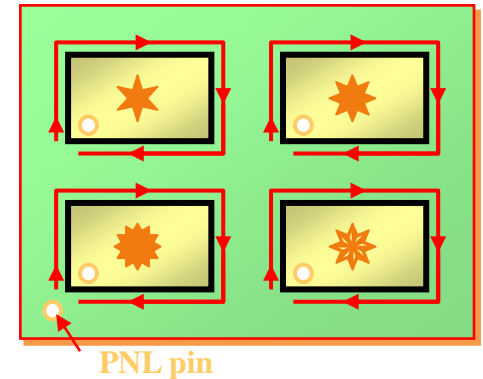
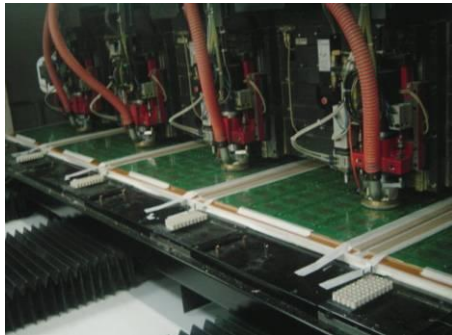

Profile milling machine



Electrical testing process

Use Ohm's law to test and determine the continuity and insulation between the PCB networks, and conduct electrical tests on open and short circuits to ensure the quality of the shipment.



Types of electrical testing:

1. Dedicated machine test

- Advantages: fast production speed
- Disadvantages: test needles cannot be recycled, high fixture cost.

Universal machine

2. (Universal on Grid) test

- Advantages: lower fixture cost
- Disadvantages: The equipment cost is high.

3. Flying probe test (Moving probe)

Does not need to make expensive fixtures, use two probes to move x, y, z to test the two ends of each line.

- Advantages: no need for fixtures and low cost
- Disadvantages: low efficiency

I . Introduction to electrical test process



- **Final inspection / laboratory**

Final inspection / laboratory is the final quality check conducted during the manufacturing.

(1) The main items of inspection:

- 1 Outline Dimension
- 2 Hole to Edge
- 3 Board Thickness
- 4 Holes Diameter
- 5 Line width/space
- 6 Annular Ring
- 7 Items in appearance and length etc.

(2) **The main project of the laboratory**

- **1. Solderability**
- **2. Peel strength**
- **3. Micro Section**
- **4. Thermal Shock**
- **5. Ionic Contamination**
- **6. Moisture and Insulation Resistance**
- **7. Impedance**
- **8. Reliability and other items.**

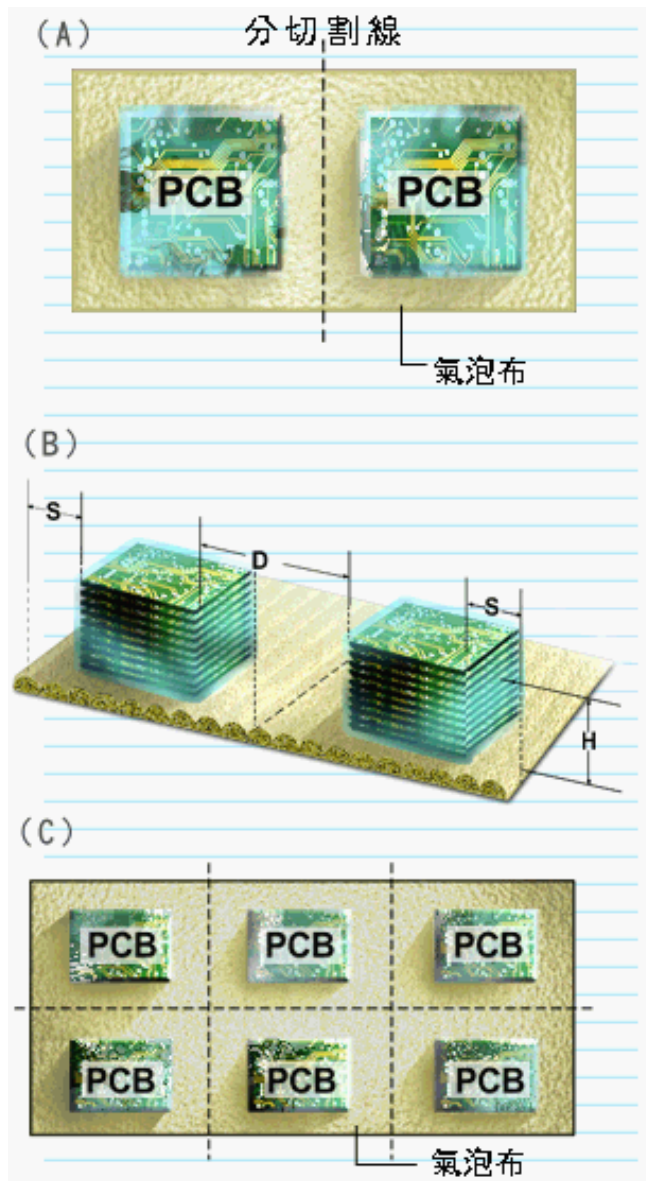

Packaging and shipping!